

Car TOP HANDRAILS

Elevator car top handrails are installed on the top of existing cabs as shown in Fig. 1 below. This addition provides a safe and secure working environment for technicians and licensed professionals to access components and trouble-shoot issues when necessary. In addition to safety, this update decreases a building's liability exposure.

Safety First...

LEGISLATION

States are adopting codes in-line with OSHA standards with regards to the installation of car top handrails to provide added building safety. For example, the state of Washington code states the following:

“A standard railing must be installed on the top of all traction elevators where the perpendicular distance between the edges of the car top and the adjacent hoistway enclosure exceeds twelve inches horizontal clearance... WAC 296-96-23119.”

(SOURCE: <http://apps.leg.wa.gov/WAC/default.aspx?cite=296-96-23117>)

WHY CONSIDER?

- Improves safety
- Relative low-cost
- Implements pro-active compliance
- Reduces liability exposure

**(There are a number of car top handrail solutions for various applications. Consult with your Fujitec sales associate to determine the best solution for your building.)*

Car Top Emergency Exit

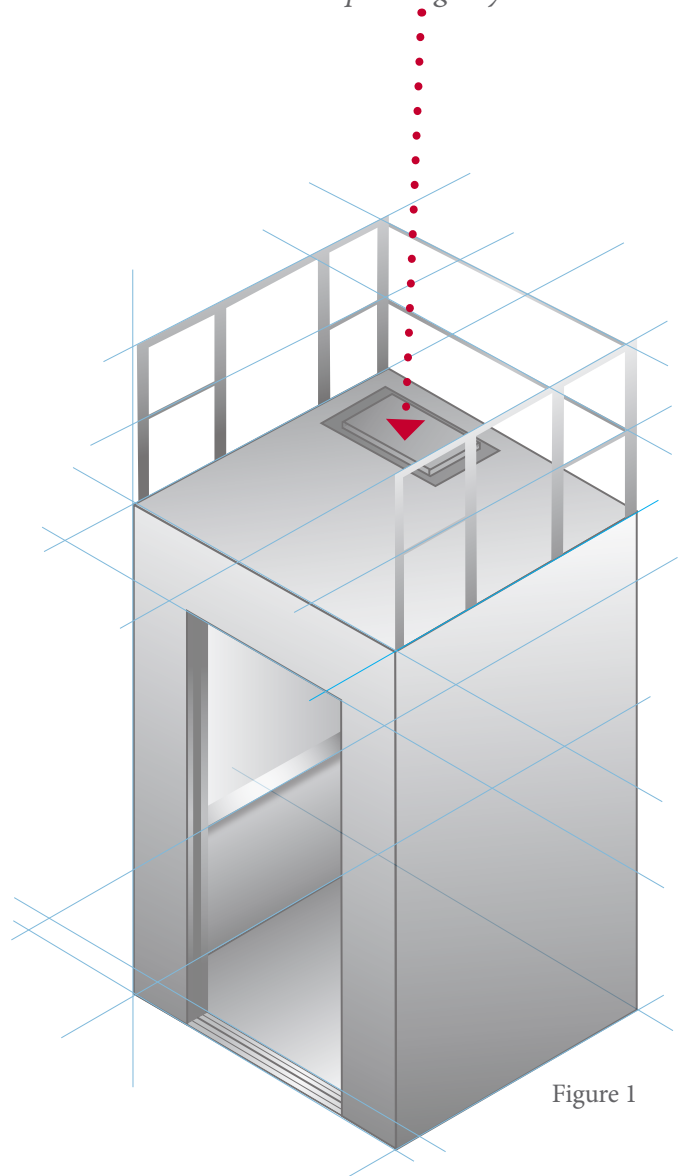

Figure 1